



Influence of macro-roughness on the leading edge of the plate on hydrodynamic losses

Influencia de la macrorrugosidad del borde de ataque de la placa sobre las pérdidas hidrodinámicas

Artem Ryzhenkov*, Aleksander Volkov, Sergey Cherepanov, Aleksey Druzhinin, Marat Dasaev, Sergey Grigoriev

National Research University "Moscow Power Engineering Institute", Russia.

*Corresponding author: RyzhenkovAV@mpei.ru

(*recibido/received: 02-octubre-2022; aceptado/accepted: 09-diciembre-2022*)

ABSTRACT

The paper presents research into the effects of macro-roughness on the leading edge of the plate imitating excrescences on the fins of humpback whales on the value of hydrodynamic losses. The authors compare calculations with experimental results obtained on a hydrodynamic flume. All studies are performed using the Ansys CFX and Autodesk CFD computer simulation packages. Based on the obtained findings, the authors make conclusions on the feasibility of applying macro-roughening on the leading edge of the plate. The conducted computational and experimental research demonstrates the positive effects of a certain configuration of spherical macro-roughness on the hydrodynamic characteristics of the plate in the case of spillage in an open-type hydrodynamic flume.

Keywords: biomimetics, hydrodynamics, CFD.

RESUMEN

El artículo presenta una investigación sobre los efectos de la macrorrugosidad en el borde de ataque de la placa que imita las excrescencias en las aletas de las ballenas jorobadas sobre el valor de las pérdidas hidrodinámicas. Los autores comparan los cálculos con los resultados experimentales obtenidos en un canal hidrodinámico. Todos los estudios se realizan utilizando los paquetes de simulación por computadora Ansys CFX y Autodesk CFD. Con base en los hallazgos obtenidos, los autores llegan a conclusiones sobre la factibilidad de aplicar macrorrugosidad en el borde de ataque de la placa. La investigación computacional y experimental realizada demuestra los efectos positivos de una cierta configuración de macrorrugosidad esférica sobre las características hidrodinámicas de la placa en el caso de derrame en un canal hidrodinámico de tipo abierto.

Palabras claves: biomimética, hidrodinámica, CFD.

1. INTRODUCTION

The latest research demonstrates that the presence of macro-roughness on the leading edge imitating excrescences on the fins of humpback whales may affect the hydro- and aerodynamic characteristics of

various objects. For instance, A.A. Druzhinin et al. (2019) report the results of computational and experimental studies of a micro-hydro turbine with a modified blade system. Therefore, it is established that the use of excrescences on the inlet edge of impeller blades promotes the ordering of flow structure in the interblade channel. This, in turn, leads to a decrease in hydraulic resistance and, consequently, to a decrease in hydraulic losses by up to 20% when the blade system leaks the fluid (Vikhlyantsev et al., 2020; Volkov et al., 2018).

2. MATERIALS AND METHODS

Study of the effects of excrescences on the plate leading edge

Following the principles described by A.A. Panin and V.S. Lagunov (2005), we applied the method based on the momentum theorem to study the distribution of velocities in tip vortices, by which the value of the drag of the streamlined body is determined. Thus, the task was set to experimentally determine the distribution of velocities in tip vortices behind the plate when spherical excrescences are placed on its inlet edge, which gives an indication of the change in the shape of the boundary layer and the value of hydraulic resistance.

Using the Autodesk Inventor computer modeling package, we modeled a plate with spherical macro-roughness on the leading edge. The configuration of spherical macro-roughness is defined by the following parameters: radius, dislocation, and number of excrescences.

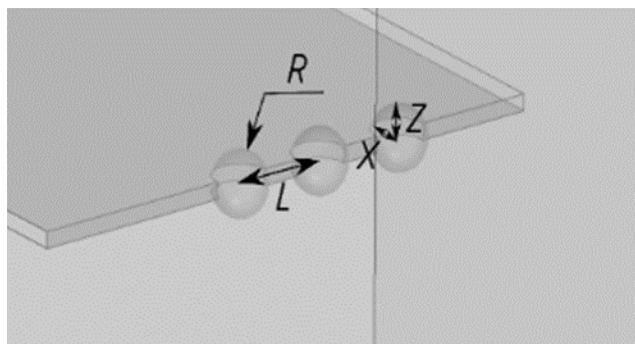

Figure 1. Parameters of spherical macro-roughness

After analyzing the results obtained in articles (Egorkina, Petrov, 2019; Isaev, 2019; Petrov et al., 2019; Semenov, Kulakov, 2019; Martynyuk et al., 2019; Protopopov et al., 2020), the fluid flow around the original plate with spherical macro-roughness of different configurations on the leading edge was analyzed in the Autodesk CFD mathematical modeling package. Velocity distribution was analyzed in tip vortices at distances of 20 mm, 30 mm, and 40 mm behind the plate (Figure 2).



Figure 2. Calculated velocity distribution in the tip vortices behind the plate

The model presents an open-type hydrodynamic flume: frame construction with 4,000 mm long glass walls and a rectangular cross section of 252 x 450 mm. Inside the tray is a 1.5 mm thick plate made using 3D

printing technology, and at a small distance from it, a Pitot-Prandtl tube to determine the speed of fluid flow in the tip vortices. The principle diagram of the hydrodynamic flume is provided in Figure 3.

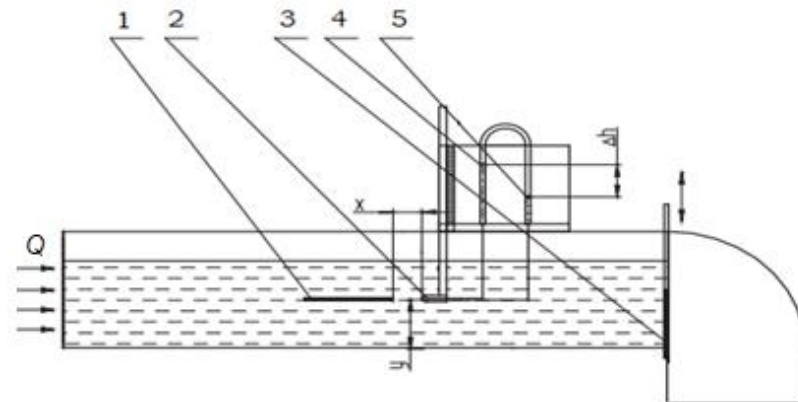

Figure 3. Principle diagram of the hydrodynamic flume. 1 – the studied plate; 2 – Pitot-Prandtl tube; 3 – regulating damper; 4 – full pressure level; 5 – static pressure level

The flow velocity is determined using the Pitot-Prandtl tube by the difference between the full and static pressure levels at the measurement point.

$$V = \varphi \cdot \sqrt{2g\Delta h}, \quad (1)$$

where Δh – the difference between full and static pressure levels and φ – coefficient accounting for the design features of the Pitot-Prandtl tube (for the tube used $\varphi = 1$).

3. RESULTS

Figures 4 and 5 show a comparison of the distribution of tip vortice velocities behind plates for the physical experiment and for computer simulations.

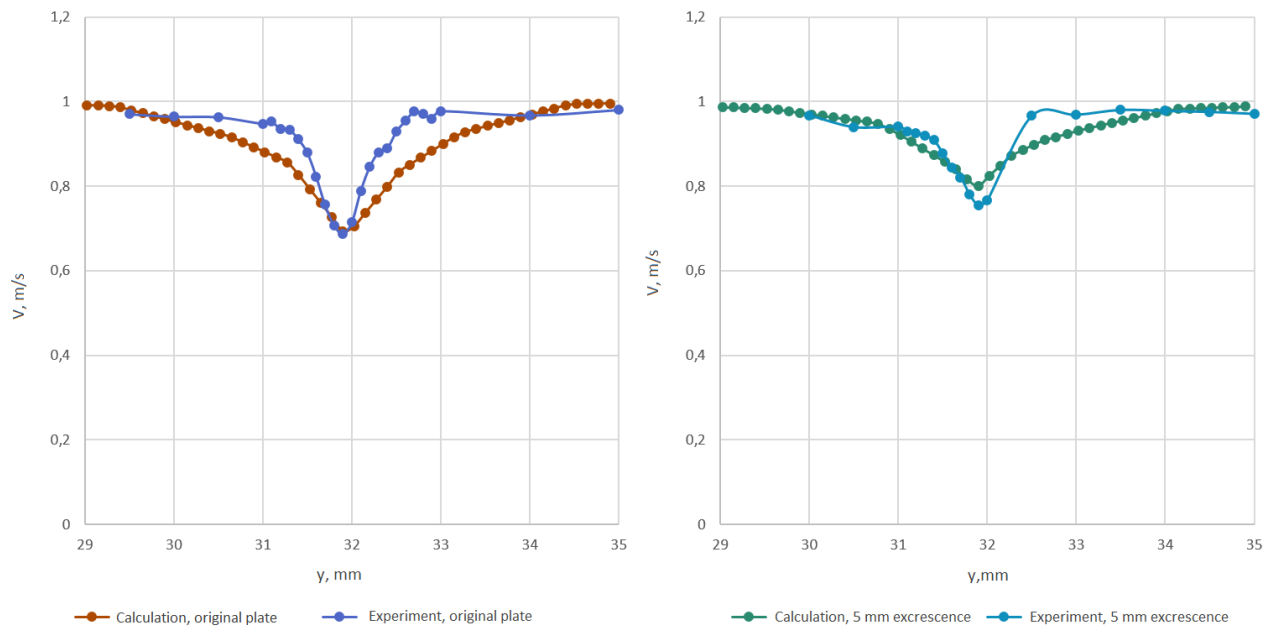

Figure 4. Comparison of calculated and experimental values of the distribution of velocities in tip vortices 20 mm behind the plate with and without spherical macro-roughness

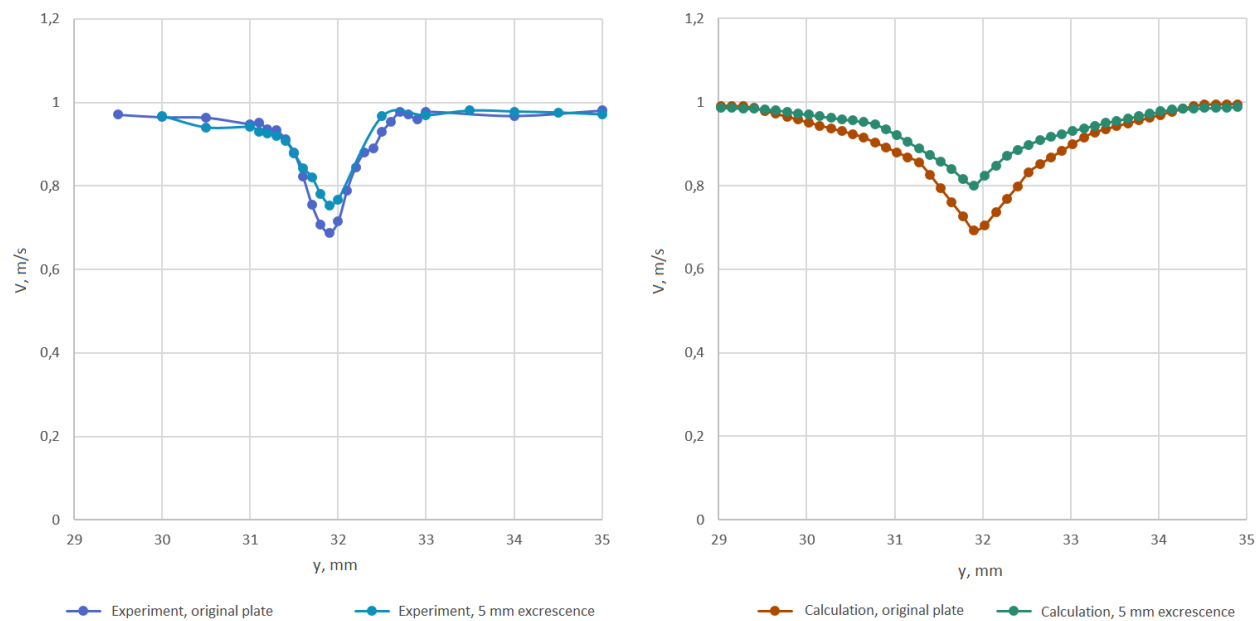

Figure 5. Comparison of calculated and experimental values of the distribution of velocities in tip vortices 20 mm behind the plate with and without spherical macro-roughness

As part of the study, we considered different configurations of spherical excrescences.

The key findings are provided in Table 1.

Table 1. Different macro-roughness configurations

Experiment №	Description	Parameters				Reduction of relative losses in %
		R, mm	Z, mm	N, mm	L, mm	
1	Original plate	-	-	-	-	-
2	3 mm excrescence	3	0	1	-	3.29
3	5 mm excrescence	5	0	1	-	3.26
4	3 mm excrescence with dislocation	3	0.75	1	-	3.44
5	two 3 mm excrescences with dislocation near each other	3	0.75	2	0	3.65
6	two 3 mm excrescences with dislocation 3 mm apart	3	0.75	2	3	3.31
7	two 3 mm excrescences near each other	3	0	2	0	3.36
8	three 3 mm excrescences with dislocation 3 mm apart	3	0.75	3	3	2.95

We also conducted computational research on the effect of the number of excrescences on the hydrodynamic losses in the case of plate spillage in the hydrodynamic flume. The investigation addressed the mutual influence of 5 mm excrescences on a plate 60 mm wide and 250 mm long and 1mm thick, i.e. we chose an area on the already examined plate. This time, however, more points behind the plate were chosen to plot tip vortices. The displacement was not only on the y-axis by 20 mm, 30 mm, and 40 mm behind the plate, but also on the x-axis: -20 mm, 0 mm, and 20 mm. Thus, there were nine experiments for each number of excrescences. For each of the experiments, the effect of using the excrescences was determined and compared with the original plate. Relative percentage loss reduction is described in Table 2.

Table 2. Relative reduction of losses in percentage with different numbers of excrescences

	20 mm - 20	20 mm 0	20 mm 20	30 mm - 20	30 mm 0	30 mm 30	40 mm - 20	40 mm 0	40 mm 20	
Plate	1.00	1.00	1.00	1.00	1.00	1.00	1.00	1.00	1.00	1.00
1 excrescence	2.52	0.77	2.83	3.31	1.37	2.03	3.78	2.09	2.14	2.32
2 excrescences	3.73	1.31	4.03	4.30	1.94	3.58	4.82	2.66	4.21	3.40
3 excrescences	6.68	0.18	4.94	7.41	-0.64	5.11	8.01	0.28	5.32	4.14
4 excrescences	7.06	2.69	5.75	7.60	3.49	5.84	8.35	4.22	7.10	5.79
5 excrescences	1.91	0.17	2.56	2.33	0.22	2.61	3.21	0.88	3.09	1.89
8 excrescences	2.84	0.94	1.99	3.51	1.77	3.49	4.19	2.40	3.93	2.78
11 excrescences	-0.15	-4.96	-0.32	-0.79	-4.79	-0.12	0.27	-3.93	0.32	-1.61

The table demonstrates that the best solution is the presence of four excrescences on the plate located at the distance of $L=3R$ apart, while a back-to-back arrangement only aggravates the hydrodynamic characteristics of the plate.

The obtained calculated values were checked on the hydrodynamic flume. The plots of velocity distribution in tip vortices are shown in Figure 6.

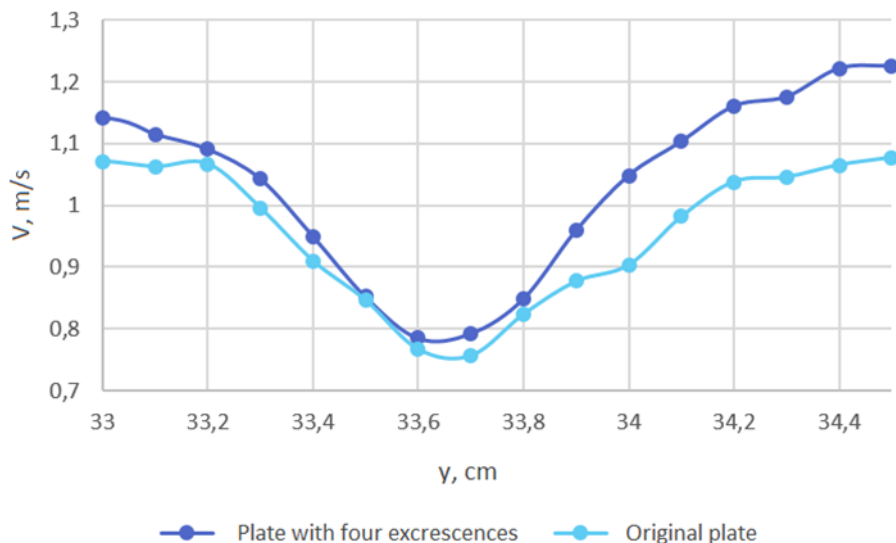

Figure 6. Velocity distribution in tip vortices behind the original plate and behind the plate with four excrescences

4. CONCLUSION

The conducted computational and experimental research demonstrates the positive effects of a certain configuration of spherical macro-roughness on the hydrodynamic characteristics of the plate in the case of spillage in an open-type hydrodynamic flume. Studies will continue to determine the optimal macro-roughness configuration to reduce hydrodynamic losses.

In the future, the results obtained can be applied in the design of impellers of hydro machines to improve the energy performance of micro HPPs. Such autonomous power sources can be used to solve the problem of power supply to remote consumers.

ACKNOWLEDGMENTS

The results were obtained within the framework of the state assignment of the Ministry of Education and Science of Russia under Assignment № FSWF-2020-0021 “Development of scientific and technical foundations for intensification of heat exchange at condensation and increase of thermohydrodynamic characteristics and wear resistance of power equipment based on the modification of functional surfaces”.

REFERENCES

- Druzhinin, A.A., Orlova, E.S., Volkov, A.V., Parygin, A.G., Naumov, A.V., Ryzhenkov, A.V., Vikhlyantsev, A.A., Šoukal, J., Sedlař, M., Komárek, M., Pochylý, F., Rudolf, P., Fialová, S. (2019). Enhancing the Efficiency of Small-Scale and Microhydroturbines Using Nature-Imitation Technologies for the Development of Autonomous Energy Sources. *Thermal Engineering*, 12, 86-96.
- Egorkina, N., & Petrov, A. (2019). The method of constructing the cavitation characteristics of a screw centrifugal pump using the methods of hydrodynamic modeling. In *IOP Conference Series: Materials Science and Engineering* (Vol. 492). Moscow: Institute of Physics Publishing. <https://doi.org/10.1088/1757-899X/492/1/012015>
- Isaev, N. (2019). The effect of design parameters of the closed type regenerative pump the energy characteristics. In *IOP Conference Series: Materials Science and Engineering* (Vol. 492). Moscow: Institute of Physics Publishing. <https://doi.org/10.1088/1757-899X/492/1/012026>
- Martynyuk, A., Petrov, A., & Kuleshova, M. (2019). Comparative analysis of the use of the spiral and bladed stators in a compact high-speed centrifugal pump with hydrodynamic modeling methods. In *IOP Conference Series: Materials Science and Engineering* (Vol. 589). Moscow: Institute of Physics Publishing. <https://doi.org/10.1088/1757-899X/589/1/012029>
- Panin, A.A., Lagunov, V.S. (2005). Uplotnitelnye elementy gidravlicheskih sistem na osnove ftoroplasta-4 [Sealing elements of hydraulic systems on the basis of polytetrafluoroethylene]. *Inj. tekhnol. Rabochii*, 10, 36.
- Petrov, A., Isaev, N., & Kuleshova, M. (2019). Test bench flow straightener design investigation and optimization with computational fluid dynamics methods. In *IOP Conference Series: Materials Science and Engineering* (Vol. 492). Moscow: Institute of Physics Publishing. <https://doi.org/10.1088/1757-899X/492/1/012036>

Protopopov, A., Belov, N., Kalugina, M., & Mukhlaeva, A. (2020). Research of dependence centrifugal pump efficiency of impeller slit seal design parameters. In IOP Conference Series: Materials Science and Engineering (Vol. 963). IOP Publishing Ltd. <https://doi.org/10.1088/1757-899X/963/1/012003>

Semenov, S., & Kulakov, D. (2019). Mathematical modeling of the mechanisms of volumetric hydraulic machines. In IOP Conference Series: Materials Science and Engineering (Vol. 492). Moscow: Institute of Physics Publishing. <https://doi.org/10.1088/1757-899X/492/1/012042>

Vikhlyantsev, A.A., Volkov, A.V., Ryzhenkov, A.V., Druzhinin, A.A., Šoukal, J., Sedlař, M., Komárek, M., Pohylý, F., Rudolf, P., Fialová, S. (2020). Povyshenie effektivnosti gidroturbin mikroGES, funkcioniruiushchikh pri peremennom napore, putem sozdaniia aperiodicheskoi lopastnoi sistemy [Increasing Efficiency for MicroHPP Hydroturbines Operating under Variable Head Pressure Using an Aperiodic Blade System]. *Thermal Engineering*, 12, 73-82.

Volkov, A.V., Ryzhenkov, A.V., Parygin, A.G., Naumov, A.V., Druzhinin, A.A., Vikhlyantsev, A.A., Šoukal, J., Sedlař, M., Komárek, M., Pohylý, F., Rudolf, P., Fialová, S. (2018). Problemy razvitiia avtonomnykh kogeneratsionnykh energeticheskikh kompleksov na osnove mikrohidroenergetiki [Matters Concerned with Development of Autonomous Cogeneration Energy Complexes on the Basis of Microhydropower Plants]. *Thermal Engineering*, 11, 32-39.